

Merlin MicroShot™ Injector

INSTRUCTION MANUAL

The *Merlin MicroShot Injector* delivers quick and reproducible manual syringe injections for gas chromatography.

KEY COMPONENTS

Figure 1 shows the components of the *Merlin MicroShot Injector* and will be referred to throughout this instruction manual.

CAUTION: Pumping a dry syringe can reduce the syringe life and compromise injector performance. Always supply solvent to the needle tip when moving the syringe plunger.

SELECTING A SYRINGE

The *MicroShot Injector* does not come with a syringe installed. These can be purchased from your distribution partner.

Figure 2 shows the syringe compatibility requirements including plunger end detail, which is important for proper function. A 10 μL syringe will give the nominal injected volume indicated for that *MicroShot Injector* and a 5 μL syringe will give half that volume. Removable or fixed needles, 23 or 26 gauge needles can all be used with the *MicroShot Injector*.

INSTALLING THE SYRINGE

1. To lubricate the **Syringe Plunger**, load approximately 1 μL of solvent into the syringe.
2. Move the **Plunger Stop** to the released position.
3. Open **Plunger Bolt**.
4. Open **Syringe Latch**.
5. Raise the **Plunger Slide** about half way.
6. Slide the Syringe Flange under the **Syringe Flange Clamp**.
7. Close the **Syringe Latch** to secure the syringe.
8. **Lower Plunger Slide** until it stops.
9. Close the **Plunger Bolt** to secure the **Syringe Plunger**.
10. Rinse with solvent to check for free plunger motion.

REMOVING THE SYRINGE

1. Open the **Plunger Bolt**.
2. Raise the **Plunger Slide** half way.
3. Open the **Syringe Latch**.
4. Remove the syringe.

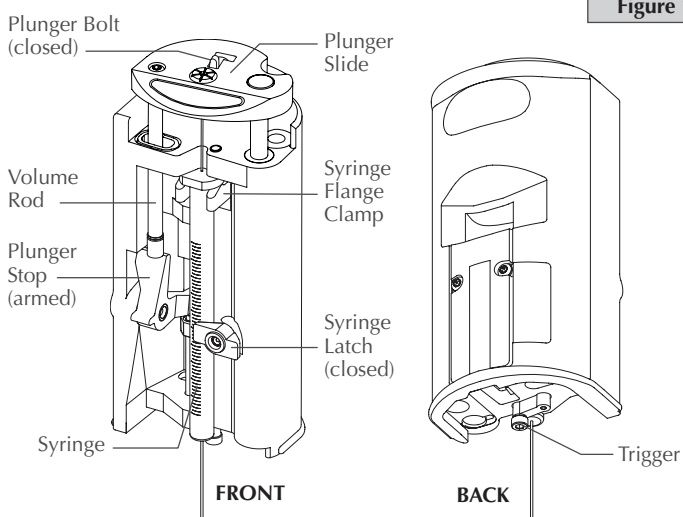

Figure 1

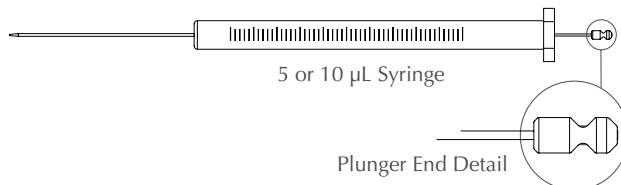

Figure 2

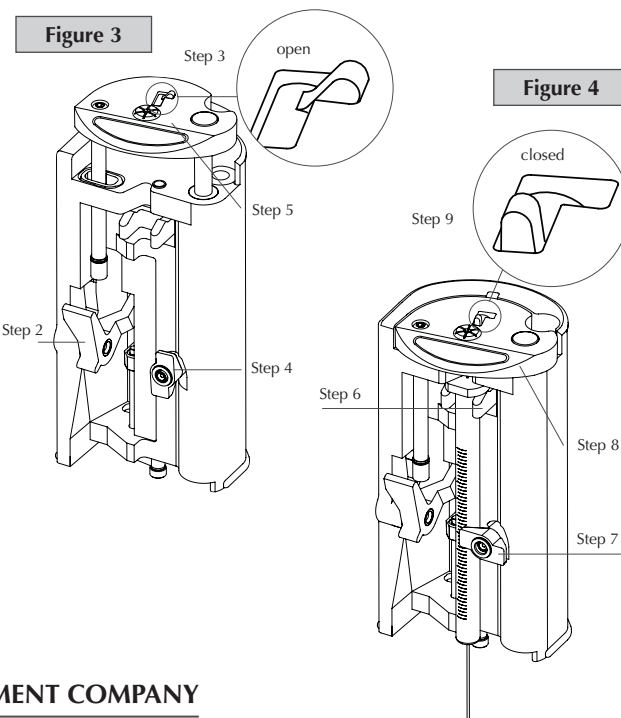

Figure 3

Figure 4

MERLIN INSTRUMENT COMPANY

Half Moon Bay, CA | Newark, DE

PREPARING FOR AN INJECTION

1. With the **Plunger Stop** in the released position, rinse and fill the syringe with sample using the **Plunger Slide**.
2. Keeping the **Plunger Slide** raised, arm the **Plunger Stop**.
3. Lower the **Plunger Slide** slowly until the **Volume Rod** comes to rest on the **Plunger Stop**.
4. Wipe the needle.
5. The **MicroShot Injector** is now filled and armed for injection.

MAKING AN INJECTION

1. Align the syringe needle with the injection port.
2. Push the needle all the way into the injection port and then withdraw the **MicroShot Injector**. The injection occurs when the **Trigger** is displaced by the top of the injection port.
3. Start the instrument.

SAFETY AND CLEANING

Please use all applicable laboratory safety procedures when using sharp objects or chemical solvents.

Laboratory goggles should be worn at all times when working with the **MicroShot Injector**.

The injector can be cleaned with warm solution of laboratory-grade detergent and rinsed with deionized water.

Dry the injector completely before use.

WARRANTY AND CALIBRATION

The **MicroShot Injector** is warranted against defects in materials and workmanship for one year from date of purchase.

Please contact your distribution partner for service or return policies.

Each **MicroShot Injector** is calibrated to deliver a stroke of the plunger slide within +/- .025 mm of nominal.

Most syringes are calibrated by the manufacturer therefore, please refer to your syringe manufacturer for calibration requirements for your particular syringe.

TIPS FOR BEST PERFORMANCE

For split injections use a small amount of glass wool in the inlet liner to prevent the sample from reaching the bottom of the liner, which would cause vaporization past the split point. Other appropriate inlet liner designs will also serve this same function. Glass wool also helps wick low volatility compounds from the tip of the syringe needle.

An easy way to verify the **MicroShot Injector** is functioning properly is as follows:

- Load and arm the syringe.
- Hold the needle tip approximately 2 cm above a piece of paper.
- Manually push the trigger and listen for an audible click.
- Look for a small spot of liquid on the paper.

TROUBLESHOOTING

PROBLEM	PROBABLE CAUSE	SOLUTION
Syringe Plunger end doesn't go into Plunger Slide.	Plunger Bolt is in the closed position.	Move Plunger Bolt to the open position (Figure 3).
Sample doesn't fill syringe.	Syringe plunger not connected to Plunger Slide.	Close Plunger Bolt (Figure 4).
	Syringe needle is plugged.	Remove and clean or replace syringe.
Microshot Injector fails to make injection.	Plunger Stop not armed before injection.	Arm Plunger Stop prior to injection (Figure 5).
	Trigger is not getting pressed in all the way.	Make sure Trigger contacts septum nut.
	Plunger Slide or syringe plunger sticking.	Remove and clean syringe. Verify free plunger movement.

Figure 5

